

## GTJZ1217RT-12m Diesel SCISSOR LIFT

Model	GTJZ-1217RT
Working Height Maximum	14m
Platform Height Maximum	12 m
Lift capacity	380 kg
Lift capacity (extension deck)	120 kg
Length ①	2.9/3.57m
Width ②	1.75 m
Height(stowed)③	2.77m
Wheel base④	2.2m
Ground clearance-center⑤	0.2m
Platform measurement ②*①	2.9*1.5 m
Extension deck measurement	1.1 m
Turning radius minimum	1.83/4.25 m
Travel speed(stowed)	4km/h
Travel speed(raised )	0.8km/h
Grade ability	35%
Sold tire	26/12-16.5
weight	4750kg
Fuel tank volume	85L
Hydraulic tank volume	62L
Drive mode	4*4*2
Steering wheel number	2
Engine	Yanmar3TNV82A-S NN-ASM ( 15.5kw/2200rpm )

### CONFIGURATION

Engine: Yanmar from Japan  
 Pump: SAUER from USA  
 Motor: SAUER from USA  
 Travel reducer:PMP from Italy  
 Valve: Sant from Italy  
 Joystick: Canplus from China  
 Sensor: Danfoss from USA

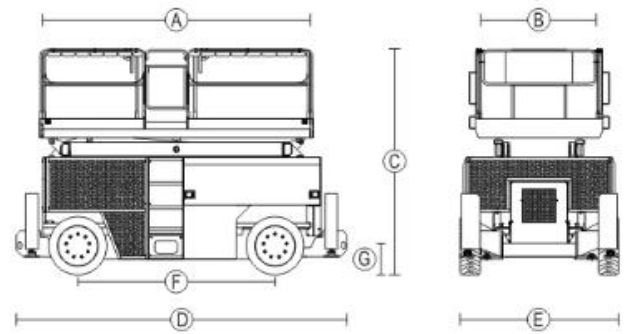

GTJZ1217RT

